

UNIVERSAL DUCT ELBOW

GRAY 6.3X6.3 TO 90°

Cable Tray
Accessories

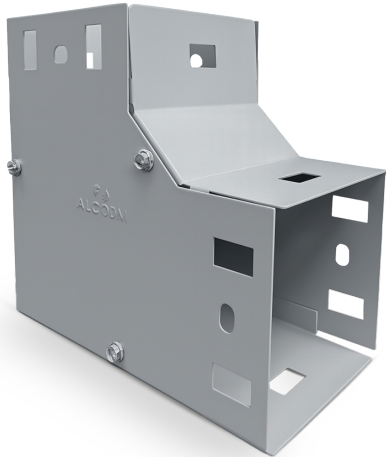

FEATURES

- Construction that guarantees durability and an excellent appearance
- A sealed system that protects electrical conductors from impacts, animals, chemicals, and other unwanted intrusions.
- Designed to be disassembled.
- Black steel sheet with an electrostatic polyester powder coating, previously degreased, phosphated, and sealed to provide high corrosion resistance.

BENEFITS

- It features an internal fold that provides greater rigidity and prevents cuts to both the installer and the cable, making it unique on the market.
- One-click connection with two self-tapping screws to improve security (built-in joint)

SPECIFICATIONS

MATERIAL	CARBON STEEL
GAUGE	20
COLOR	ELECTRONIC GRAY
PAINT TYPE	SMOOTH HYBRID
PAINT APPLICATION	ELECTROSTATIC POWDER COATED AT 190°C
JOIN INCLUDED	NO
WEIGHT	2 KG

ISOMETRIC

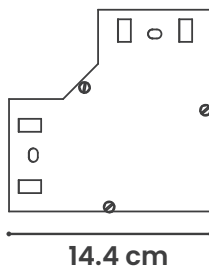
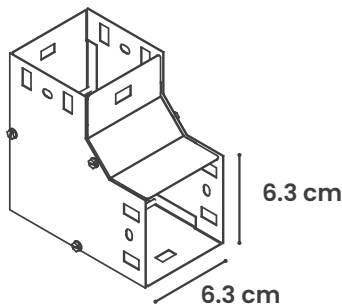

CONFIGURATIONS

CERTIFICATIONS

CODE	DESCRIPTION	H	W	D
4KDUACOACGA6390	UNIVERSAL DUCT ELBOW GRSY 6.3X6.3 TO 90°	6.3	6.3	14.4



HQ Manufacturing Facility
Gómez Palacio
871 750 00 03, 79
871 750 11 52, 62

Guadalajara Branch
331 368 80 28
333 162 08 75

Monterrey Branch
818 191 99 91
811 520 08 53

Mérida Branch
999 445 62 12

Chihuahua Sales Office
614 293 96 54

Mexico City Sales Office
567 004 20 92

*Specifications and dimensions are subject to change without notice. | Dimensions in cm

APRIL 2026