

MEASURE CABINET

70x80x35 WITH WOOD



FEATURES

- Designed to protect both electrical equipment and the users using it.
- Their mounting brackets allow the installer to quickly secure them to various surfaces.

APPLICATIONS

- Ideal for protections of electrical and electronic devices, motor controls, and electrical wiring distribution, among other applications.

ISOMETRIC

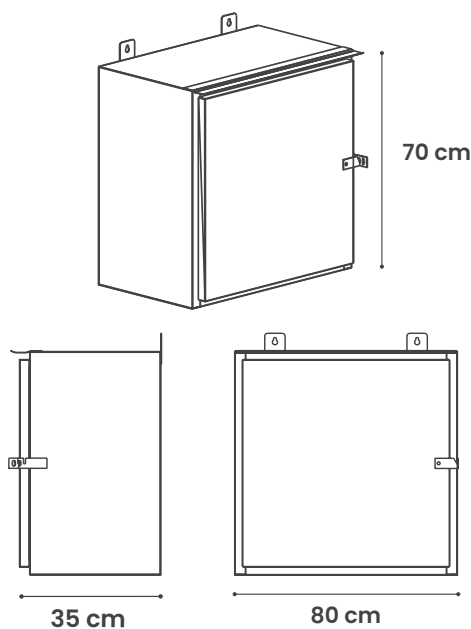

SPECIFICATIONS

MOUNTING	SURFACE-MOUNT
MATERIAL	CARBON STEEL SHEET
GAUGE	20
CABINET COLOR	GRAY (ANSI 61)
PAINT TYPE	TEXTURED POLYESTER
PAINT APPLICATION	ELECTROSTATIC POWDER COATING
MOUNTING PLATE	YES (WOOD)
MOUNTING PLATE DIMENSIONS	50X50X1.6 CM
HINGED	TUBULAR
TYPE OF LOCK	PADLOCK HOLDER
TYPE OF GASKET	N/A
WEIGHT	13.4 KG

CONFIGURATIONS

CODE	DESCRIPTION	H	W	D
2KMESOACGA7080M	MEASURE CABINET 70X80X35 WITH WOOD	70	80	35

CERTIFICATIONS



HQ Manufacturing Facility
Gómez Palacio
871 750 00 03, 79
871 750 11 52, 62

Guadalajara Branch
331 368 80 28
333 162 08 75

Monterrey Branch
818 191 99 91
811 520 08 53

Mérida Branch
999 445 62 12

Chihuahua Sales Office
614 293 96 54

Mexico City Sales Office
567 004 20 92